



MODELLING HYDROTHERMAL SYNTHESIS OF OXIDE MATERIALS IN AUTOCLAVE REACTORS WITH CONSIDERING NATURAL CONVECTION

F. I. Sharikov and I. V. Sharikov*

Ph.D., Leading Research Scientist, *Saint-Petersburg Mining University, St. Petersburg, Russia.*

*Doctor of Technical Sciences, Professor, *Saint-Petersburg Mining University, St. Petersburg, Russia.*

Article Received on 01/08/2019

Article Revised on 21/08/2019

Article Accepted on 11/09/2019

***Corresponding Author**

Dr. I. V. Sharikov

Doctor of Technical Sciences, Professor, *Saint-Petersburg Mining University, St. Petersburg, Russia.*

ABSTRACT

Hydrothermal synthesis is widely used for the production of various nanodispersed oxide materials. Reactions under hydrothermal conditions are complicated and usually they are accompanied with heat generation or heat absorption. Heat flux calorimetry is a powerful instrument for kinetic study and developing mathematical models of hydrothermal reactions. In order to apply the kinetic data to reactors of

larger volume one should take into account heat transfer, mass transfer phenomena and the possibility of non-uniform temperature distribution in a definite apparatus at the chosen initial conditions in course of hydrothermal synthesis. To predict the reaction course in a larger apparatus a mathematical model of the hydrothermal process has been developed. It takes into account natural convection inside a hydrothermal reactor together with the chemical reaction. Convective flows can be described at the base of Bussinesque approach. The differential equations system may be solved with applying a dedicated ConvEx program package that takes into account size and geometry of the reactor, reaction mixture properties, heat transfer peculiarities inside and outside and heat generation due to chemical reaction.

KEYWORDS: Hydrothermal synthesis, mixing, natural convection, scaling, autoclave, reactor, mathematical models, partial differential equations.

INTRODUCTION

The experimental high pressure vessel of C80 calorimeter (SETARAM Instrumentation) that has been used in the experimental work can be considered as a kinetic reactor with rather small temperature and concentration (or conversion) gradients that can be neglected. This approach makes it possible to apply ordinary kinetic models and facilitate the mathematical processing of experimental results. The reaction kinetics and heat generation kinetics can be effectively studied and corresponding mathematical models can be developed. But if we want to scale up the process we need to investigate the effect of mass transfer intensity and take into account temperature gradients together with the kinetics of chemical transformations in order to reproduce the synthesis conditions. In many cases mass and heat transfer in a hydrothermal reactor is provided via natural convection. In this work we estimated the effectiveness of mixing in the reaction vessel of the calorimeter and in the pilot hydrothermal reactor of a larger volume. The Boussinesque approximation was used as a basis for creating the mixing model due to natural convection. The calculation was performed in ConvEx [1] program package, which allows to perform simulation of the temperature and concentration fields in reactors of various size and geometry.

The mathematical model based on the Boussinesque approximation can be written as follows. We decompose the equation of state for a liquid $\rho = \rho(T, a^{(1)}, \dots, a^{(NC)}, p)$ by the first powers of increments of independent variables:

$$\rho = \rho_0 + \left(\frac{\partial \rho}{\partial T}\right) T' + \sum_{i=1}^{NC} \left(\frac{\partial \rho}{\partial a^{(i)}}\right) a^{(i)'} + \left(\frac{\partial \rho}{\partial p}\right) p' \quad (1)$$

Where $T', a^{(i)'}, p'$ - are deviations from the mean (usually initial) values. As a result, we get that:

$$\rho = \rho_0(1 - \beta_T T'), \text{ or } \beta_T T' = \frac{\rho_0 - \rho}{\rho_0} \equiv \frac{\Delta \rho}{\rho_0}, \text{ where } \beta_T = -\frac{1}{\rho_0} \left(\frac{\partial \rho}{\partial T}\right) \quad (2)$$

Here p is the motion-related pressure deviation from hydrostatic pressure. With this approach, the equation of continuity (mass balance) is transformed into an incompressibility condition:

$$\nabla \cdot \mathbf{V} = 0 \quad (3)$$

For the cylindrical coordinates system the incompressibility condition is as follows:

$$\frac{\partial(rV_r)}{\partial r} + \frac{\partial V_\varphi}{\partial \varphi} + \frac{\partial rV_z}{\partial z} = 0 \quad (4)$$

Where V_r , V_φ , V_z are the corresponding projections of the velocity vector on the coordinate axis. The model based on these approximations adequately describes the natural convection processes in liquids. Caution is required in case when this model is extended to processes in gases (or compressible liquids).

Formation of the equations system

In the numerical solution of incompressible fluid problems, two main approaches are used. They are based on the possibility to write equations in natural “velocity-pressure” variables (V , p) or in the variables of “current-vorticity function” (ψ , ω). The advantages and disadvantages of both approaches are well known. As a rule simulation of two-dimensional problems is more efficient in variables (ψ , ω). Omitting mathematical calculations, one can write down the corresponding systems of equations.

Cylindrical Coordinates

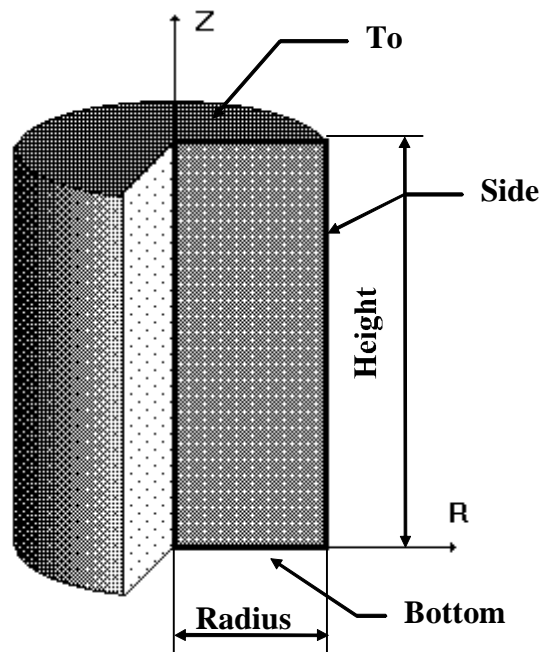

Figure 1: Vertical cylindrical reactor.

The reactor is considered to be filled only partially, so its **Height** is the distance from the bottom to the free surface.

$$\begin{aligned}
 \frac{\partial \omega}{\partial t} + u \frac{\partial \omega}{\partial r} + v \frac{\partial \omega}{\partial z} &= v \left(\frac{\partial^2 \omega}{\partial r^2} + \frac{3}{r} \frac{\partial \omega}{\partial r} + \frac{\partial^2 \omega}{\partial z^2} \right) - \frac{\beta_T g}{r} \frac{\partial T}{\partial r} \\
 \frac{\partial^2 \psi}{\partial r^2} - \frac{1}{r} \frac{\partial \psi}{\partial r} + \frac{\partial^2 \psi}{\partial z^2} &= \omega r^2 \\
 \frac{\partial T}{\partial t} + u \frac{\partial T}{\partial r} + v \frac{\partial T}{\partial z} &= a \left(\frac{\partial^2 T}{\partial r^2} + \frac{1}{r} \frac{\partial T}{\partial r} + \frac{\partial^2 T}{\partial z^2} \right) + \frac{1}{\rho c_p} q \\
 \frac{\partial a^{(i)}}{\partial t} + u \frac{\partial a^{(i)}}{\partial r} + v \frac{\partial a^{(i)}}{\partial z} &= w^{(i)} \quad i = 1, \dots, NC \\
 u = \frac{1}{r} \frac{\partial \psi}{\partial z} \quad v = -\frac{1}{r} \frac{\partial \psi}{\partial r} &
 \end{aligned} \tag{5}$$

The function of current

Since the structure of the flow is represented graphically by iso-lines of the stream function, it is useful to recall the physical meaning of these lines.

First, the iso-lines of the current function (i.e., the lines along which the stream function assumes constant values) coincide with the current lines (i.e., the lines at each point of which the direction of the tangent to the line coincides with the direction of the velocity vector).

$d\psi = \nabla\psi \cdot d\mathbf{r} = \nabla\psi \cdot d\lambda \mathbf{V} = 0$ differential ψ along the stream-line. Therefore, ψ is the differential. We used the fact that the gradient of a scalar function is a vector directed along the normal surface to an iso-surface. In this case $d\lambda$ is a scalar parameter.

In polar coordinates

$$d\psi = \frac{\partial \psi}{\partial r} dr + \frac{\partial \psi}{\partial \varphi} d\varphi = -v dr + r u d\varphi; \quad dr = u d\lambda, \quad d\varphi = \frac{v}{r} d\lambda \Rightarrow d\psi = 0; \text{ along the stream-line.} \tag{6}$$

Second, if we take two iso-lines and calculate the difference - it is possible to understand the physical meaning of ψ that corresponds to the value of this difference. To do this it is necessary to return to the original three-dimensional problem. In a three-dimensional space these iso-lines are located in the cross section of common "current surfaces".

In the case of a vertical reactor, this difference is equal to the flow rate of the liquid through the part of the sector bounded by these iso-surfaces into one radius orthogonal to the Z axis.

Simulation results for the reactor of 1 L volume

A dedicated program package ConvEx was developed in Russian Scientific Center “Applied Chemistry” (St. Petersburg) to make it possible to solve the system of differential equations of this model. It implements a grid method for solving the equations that allow to describe the process of heating the reaction mixture under natural convection conditions within the liquid phase. The corresponding simulation results are presented at various times when we need the isothermal mode 190°C inside the reactor and temperature 240°C at the reactor wall is set and the reactor fill factor is 60% (the fastest nonlinear isothermal output).

At the initial time period, the temperature gradients inside the reactor are very large. After one hour from the beginning of heating the maximum temperature difference inside is less than 20°C. The entire volume of the reaction mixture inside the reactor is permeated with circulating currents, and the temperature values on the isotherm lines become very close, i.e. the reactor becomes close to the ideal mixing apparatus. The location of the thermocouple well at the center of the apparatus also contributes to better mixing, since the thermocouple helps to destroy the circulation circuits and intensifies the mixing. The results of modeling the heating process in a 1 liter reactor are presented below, the scheme of experimental setup is given in Fig. 2, and its general view is presented in Fig. 3.

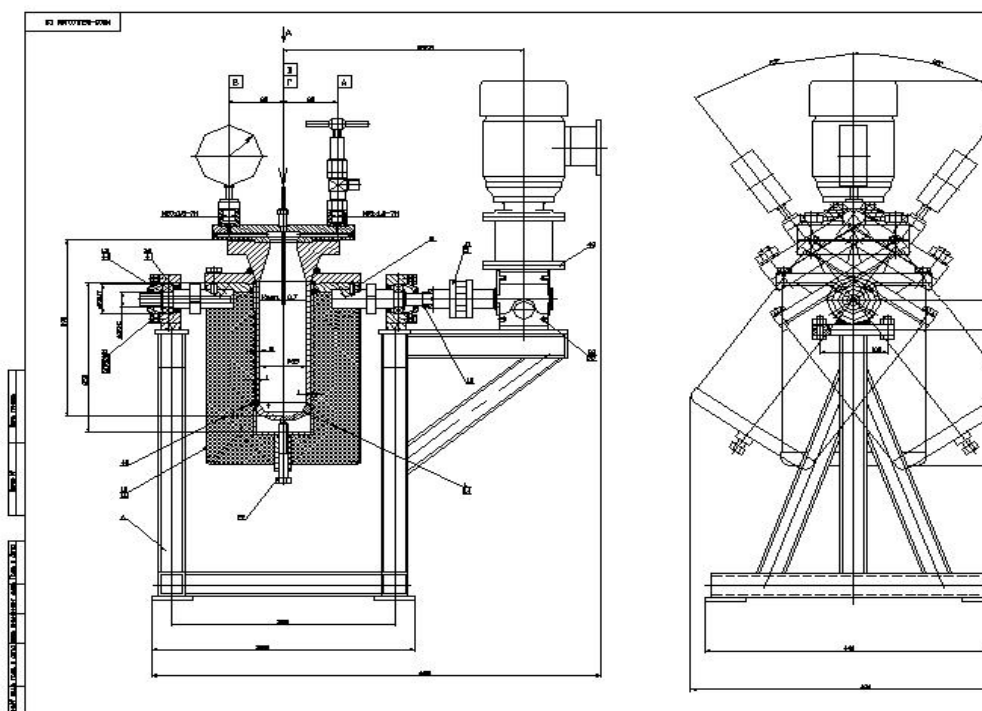

Figure 2: Scheme of the experimental set-up with an autoclave reactor with mixing of the reaction mass due to swinging around the vertical axis.



Figure 3: General view of the autoclave reactor setup for synthesis of various nanomaterials under hydrothermal conditions.

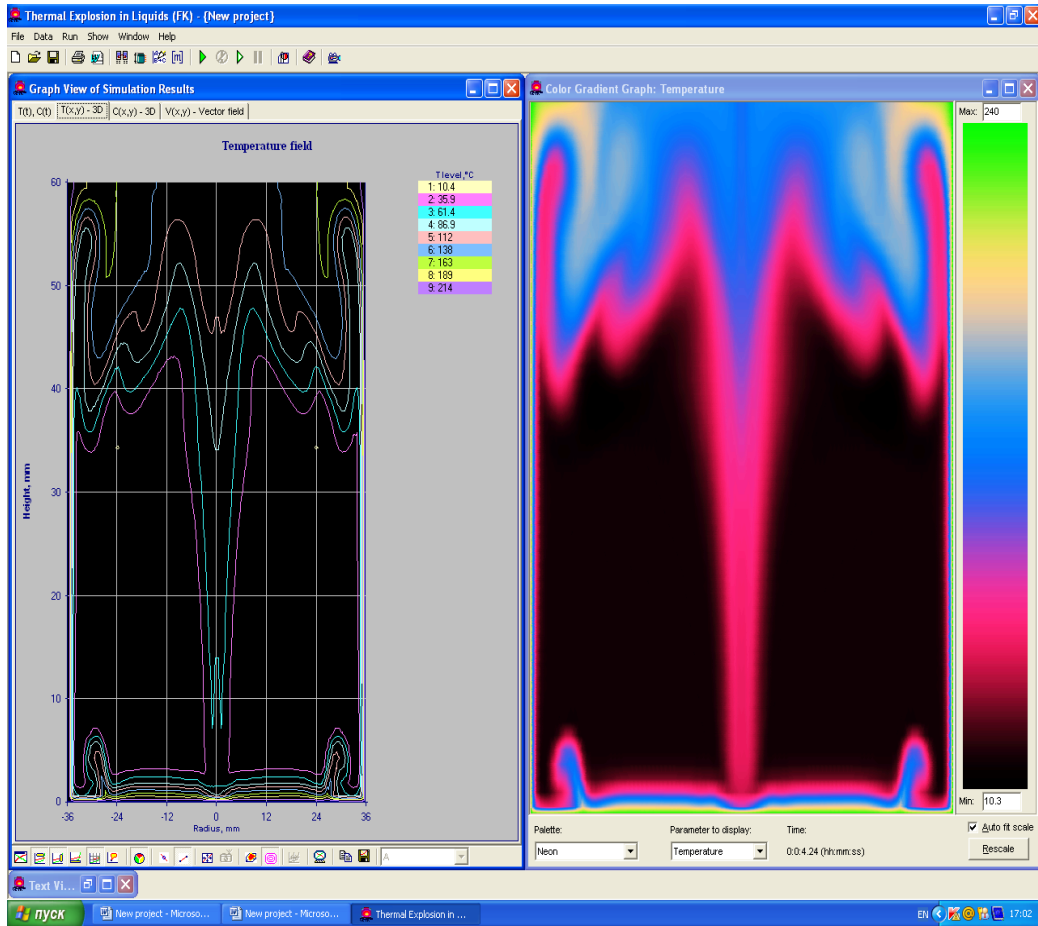

Figure 4: Temperature distribution field in the 1 L reactor at 4 min after the start of heating.

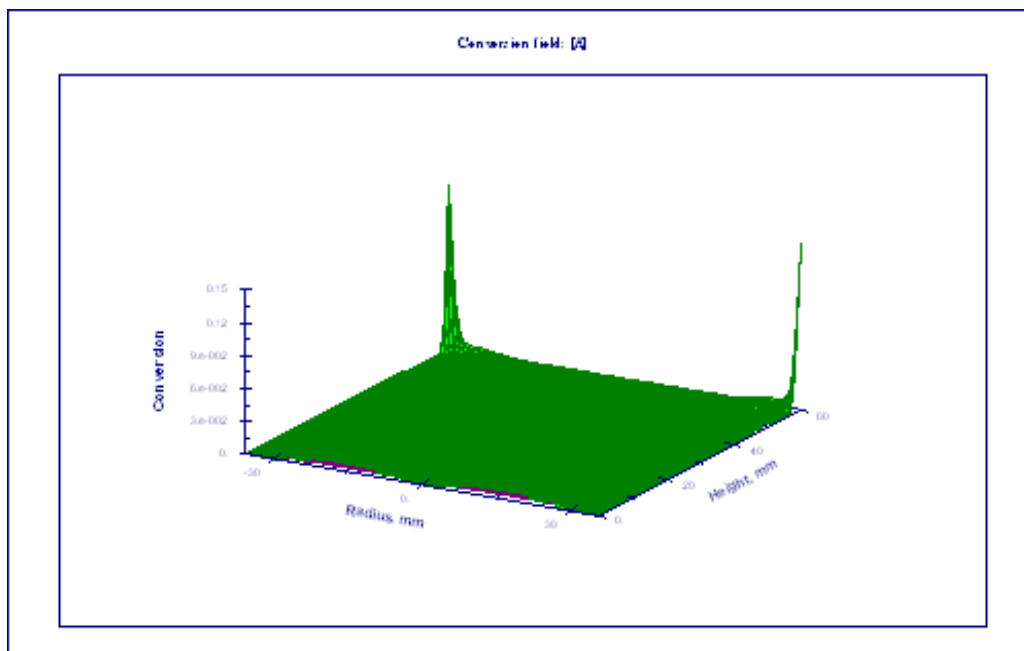

Figure 5: Conversion distribution field in the 1 L reactor at 4 min after the start of heating.

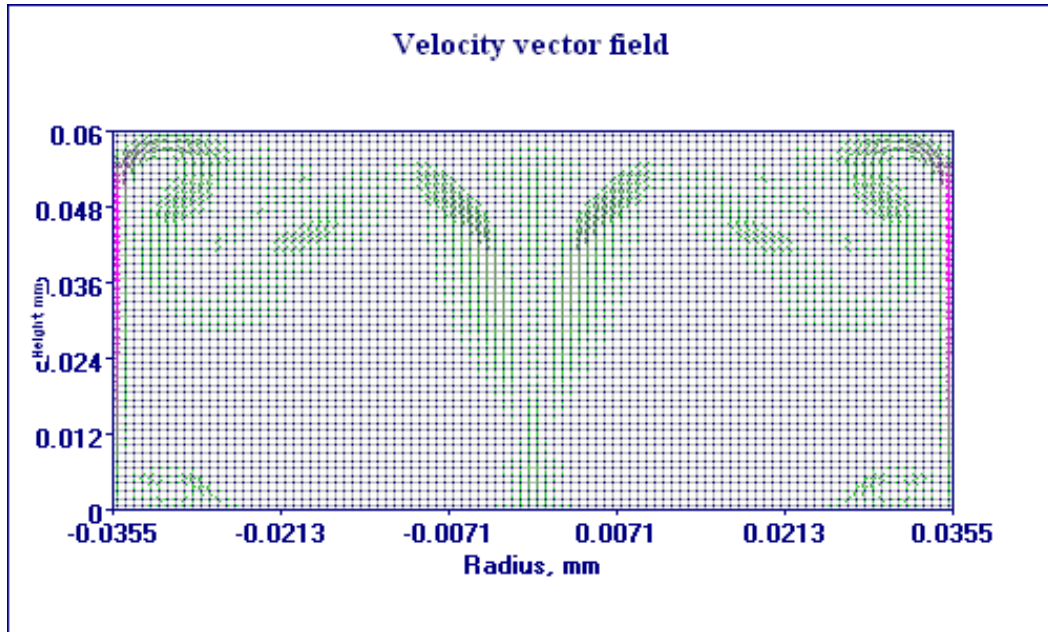

Figure 6: Vector of velocity distribution field in the 1 L reactor at 4 min after the start of heating.

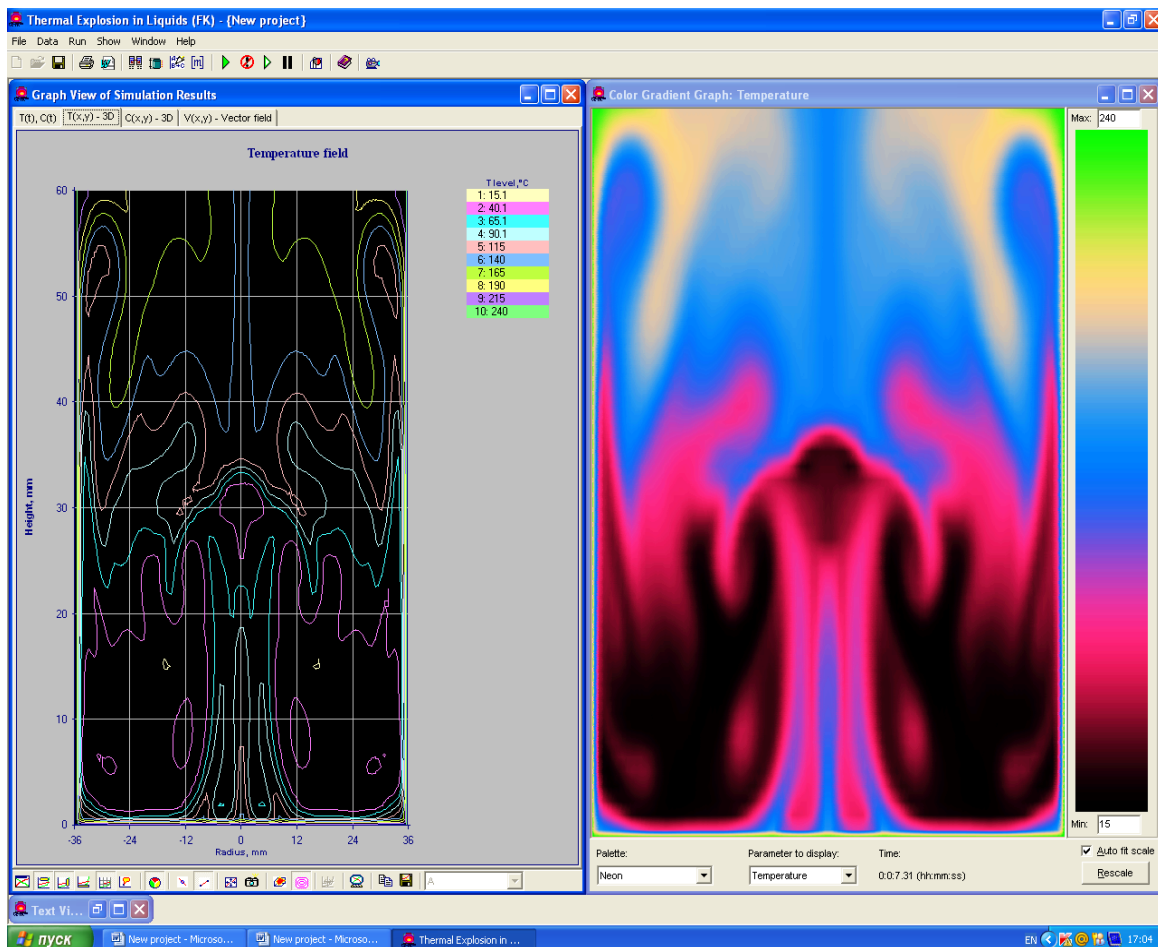

Figure 7: Temperature distribution in the 1 L reactor at 7.5 min after the start of heating.

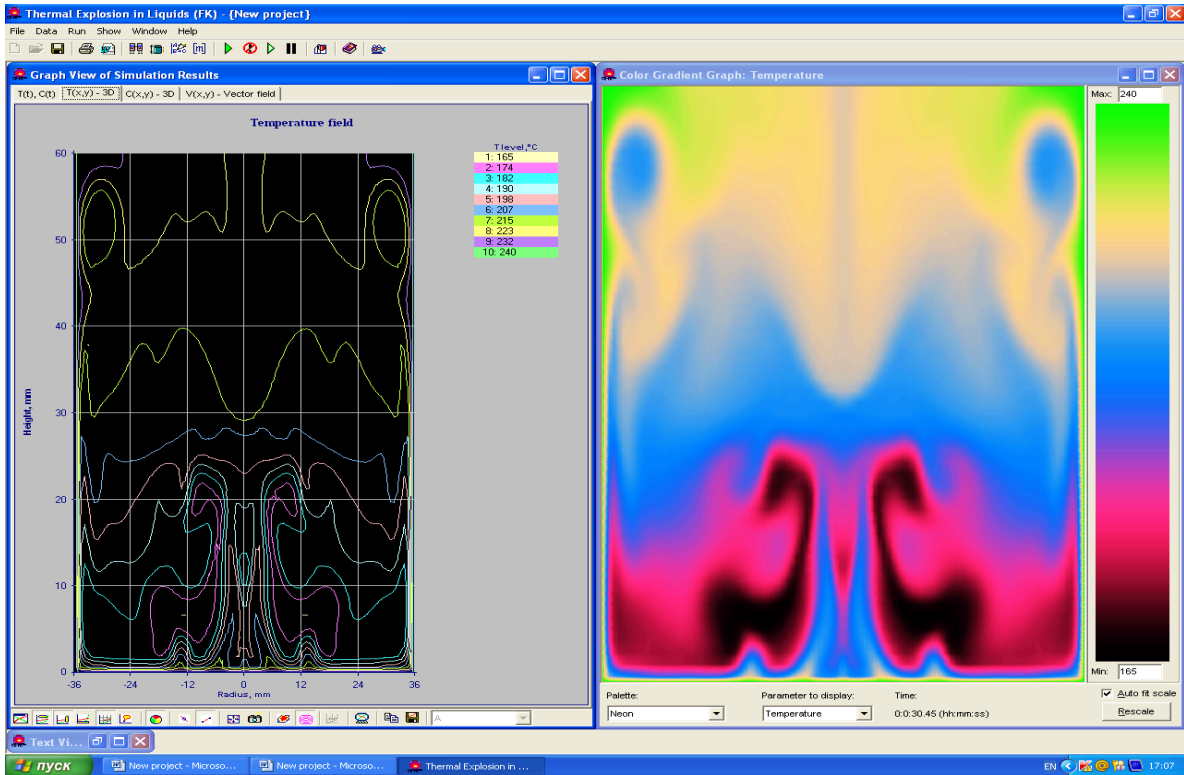

Figure 8: Temperature distribution in the 1 L reactor at 45 min after the start of heating.

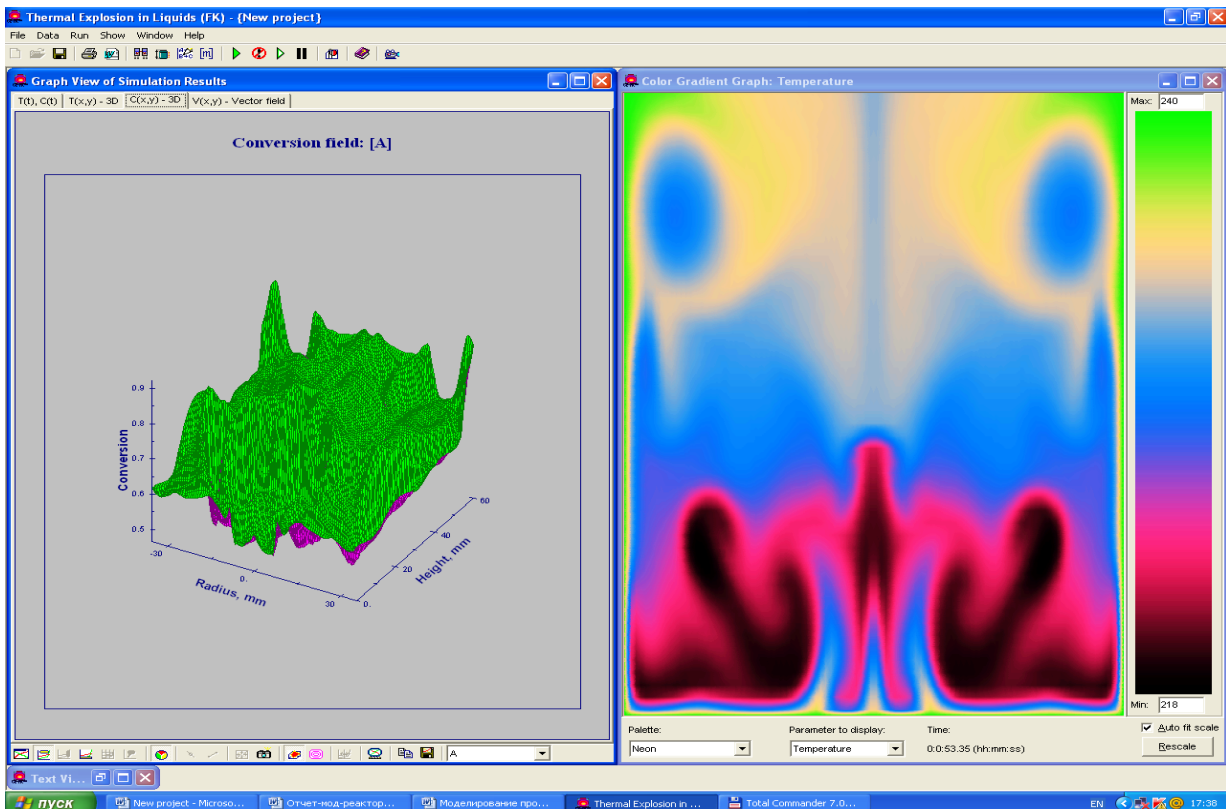

Figure 9: Temperature and conversion distribution in the in the 1 L reactor at 1 h after the start of heating.

The results of modeling for the kinetic micro-reactor 8.5 mL

Kinetic study of hydrothermal synthesis and analytical characterization of the reaction products were performed using a Calvet C80 calorimeter (SETARAM Instrumentation) and high pressure reaction vessels (in fact, micro-reactors) with a useful volume of ~ 8.5 cm³. The difference in size and volume compared to the large reactor is ~2 orders of magnitude, whereas shape of the vessel and the general principle of its heating are similar – heat transfer to the walls of the ampoule from the calorimetric block, but everything is performed much more effectively, the gaps are minimal, the entire vessel sits deeply inside the homogeneous hot zone and no any heat losses are available. Hence it is of interest to estimate the temperature and concentration field in such a micro reactor and to understand how close it is to an ideal kinetic reactor and also to compare the results with those in the larger reactor. In case of a noticeable difference it can also affect the properties of final product and we need to find an optimal temperature mode in this case.

Analysis of simulation results indicates that heating in the smaller vessel in case of an exponential heating mode is noticeably faster, and even the qualitative pattern of temperature field in two various vessels does not coincide. Hence the kinetic model and product analysis results obtained in the 8.5 cm³ vessel cannot be directly used to predict hydrothermal synthesis process in a 1 liter or larger reactor, as natural convection role in formation the reaction mixture temperature field is the key one for the larger apparatus, temperature gradients are noticeable and exist for a long time compared to the small reactor. Even after 1 h of isoperibolic heating start the estimated maximum temperature difference within the reaction mixture is still 22°C (see Fig. 9). And the temperature in the reactor becomes already fairly uniform after 2.5 h of the heating start. The volume and shape of the device both affect the overall speed and peculiarities of the convection process. Kinetic model of the process together with natural convection simulation make it possible to select the operating mode of a large reactor based on the experimental data and kinetic modeling for the hydrothermal reaction studied in the calorimetric vessel.

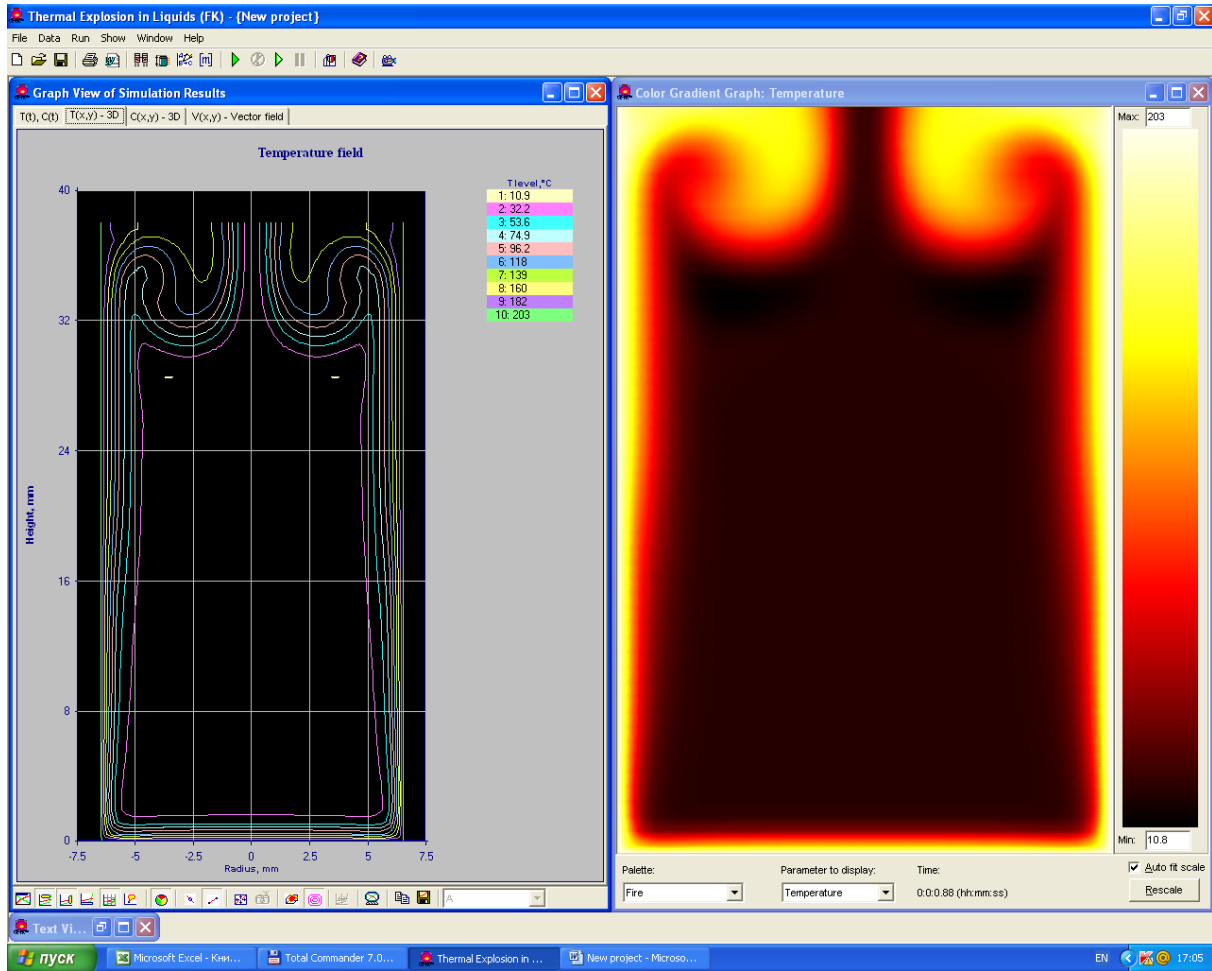

Figure 10: Temperature distribution in the in the experimental vessel of calorimeter (8.5 mL) at 1 min after the start of heating.

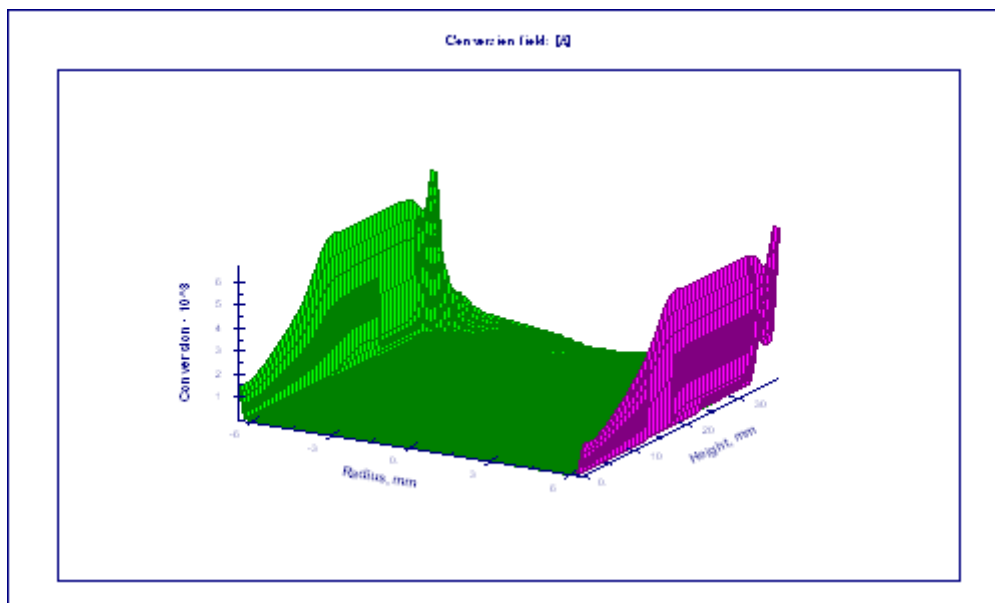

Figure 11: Conversion distribution in the in the experimental vessel of calorimeter (8.5 mL) at 1 min after the start of heating.

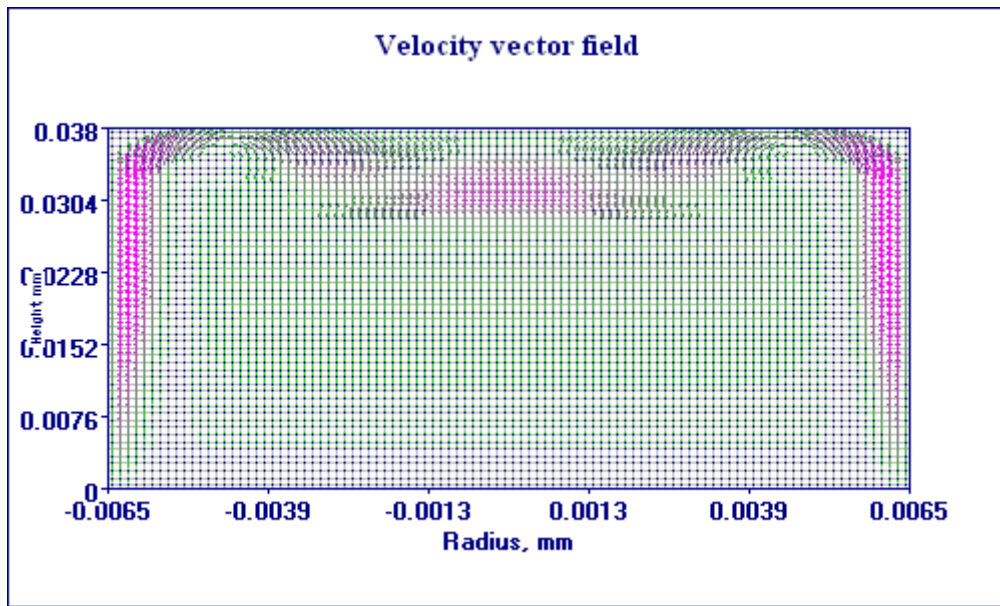

Figure 12: Velocity vector field in the experimental vessel of calorimeter (8.5 mL) at 1 min after the start of heating.

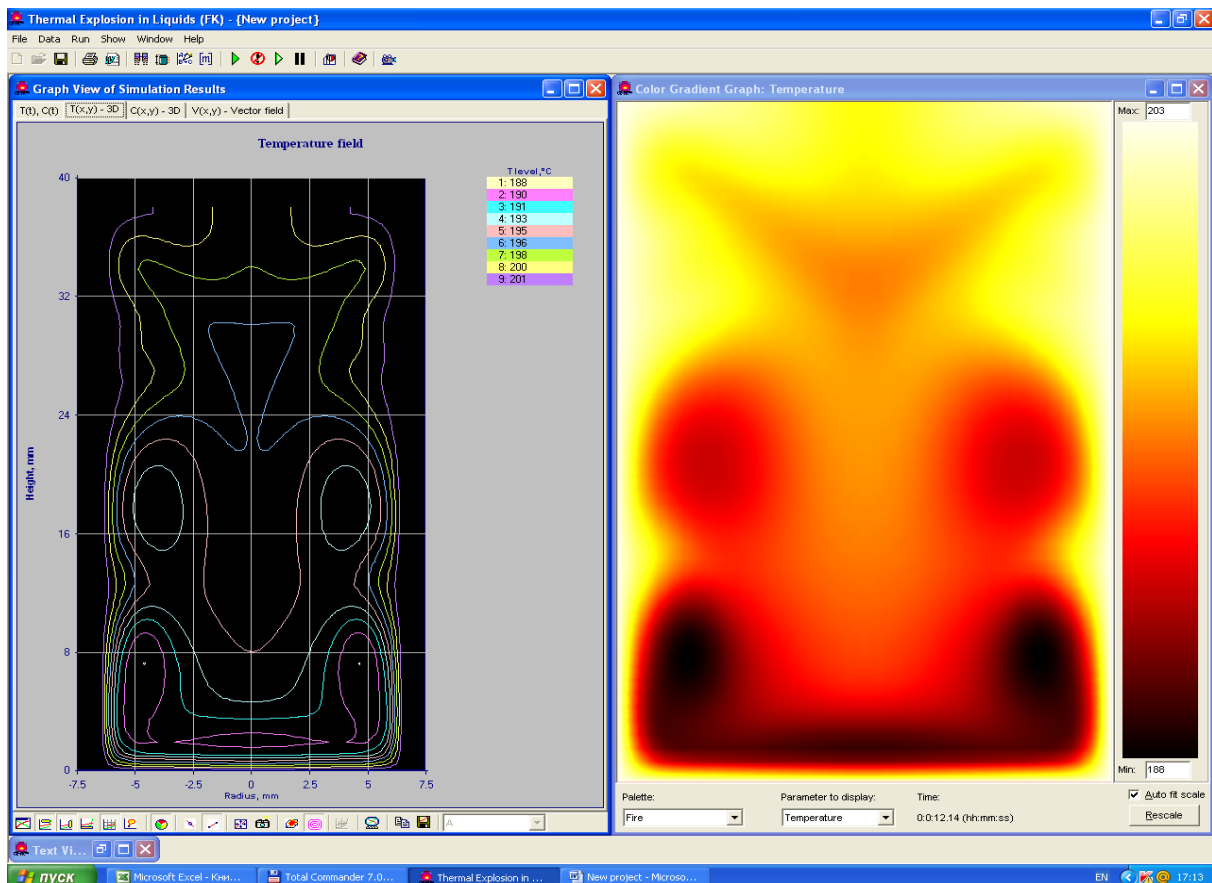

Figure 13: Temperature distribution in the in the experimental vessel of calorimeter (8.5 mL) at 12 min after the start of heating.

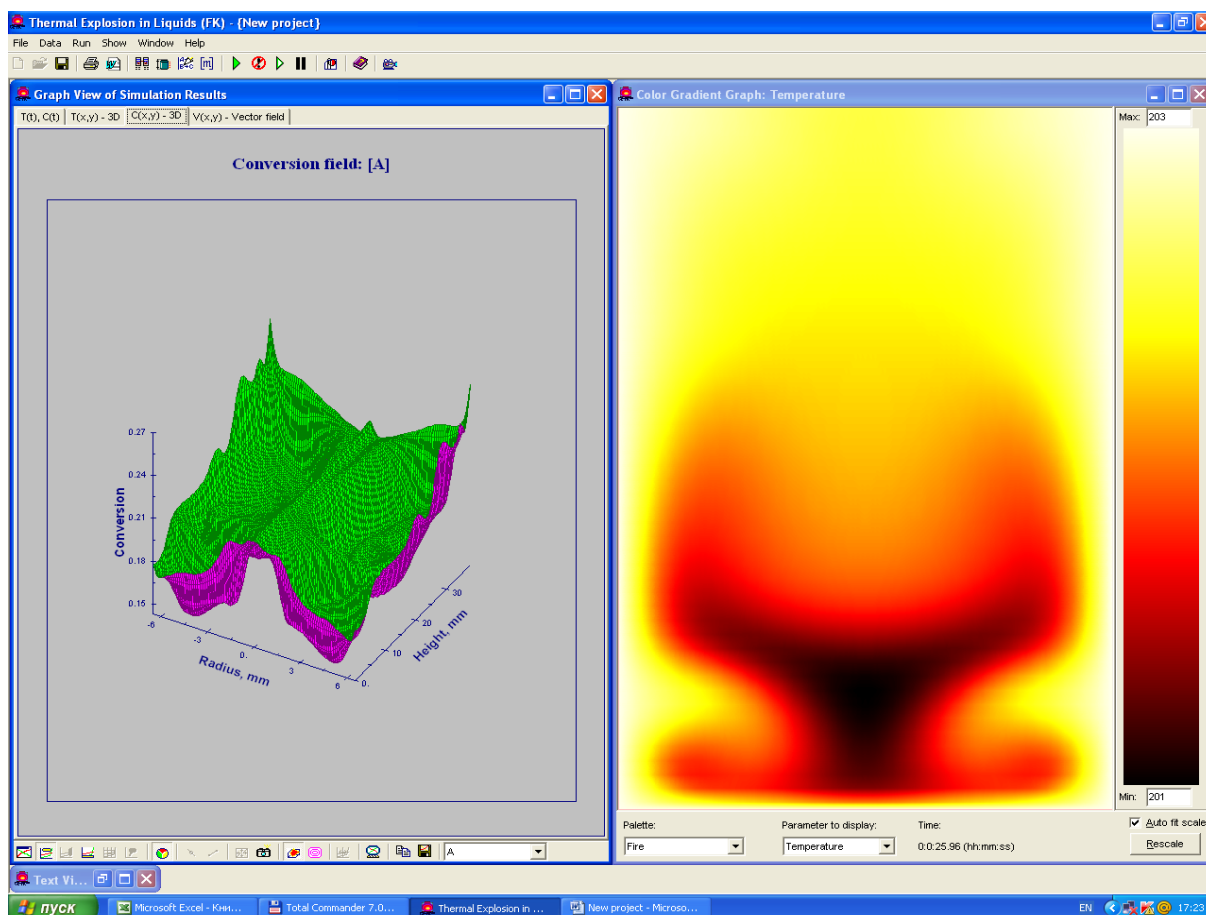

Figure 14: Temperature and conversion distribution in the in the experimental vessel of calorimeter (8.5 mL) at 26 min after the start of heating.

CONCLUSION

It was found that temperature and conversion distributions in the 8.5 cm³ calorimetric vessel and in the 1 liter hydrothermal reactor were rather different at similar initial conditions from the very beginning. This indicates of the necessity to estimate rigorously the natural convection and heat transfer phenomena at scaling the hydrothermal synthesis for each chosen temperature mode in case of the reactor of a bigger volume without mixing. An optimal temperature mode and forced convection can both improve the situation. But it should be noticed that, i.e., mechanical mixing cannot be directly introduced in case of a larger reactor without a corresponding study as it can unpredictably affect the morphological characteristics of the final product.