



### ADVANCEMENTS IN MOTOR DRIVE SYSTEMS USING FOPID CONTROLLED BOOTSTRAP CONVERTER WITH SVM INVERTER

A. Vishnu Kumar<sup>1\*</sup> and V. Jayalakshmi<sup>2</sup>

<sup>1</sup>Research Scholar Department of EEE, BIHER.

<sup>2</sup>Associate Professor Department of EEE, BIHER.

Article Received on 09/02/2024

Article Revised on 29/02/2024

Article Accepted on 21/03/2024



\*Corresponding Author

A. Vishnu Kumar

Research Scholar  
Department of EEE,  
BIHER.

#### ABSTRACT

The SVM inverter is used in this research, which is based on the Bootstrap converter. The goal of this research is to use a fractional-order-PID controller to improve the speed regulation of a boot strapped converter-inverter feed Induction Motor drive (BSC-SVMIIM). This project coordinates the investigation of BSC- SVMIIM systems controlled by PI and FOPID. To improve the voltage-gain, the BSC is recommended between the rectifier and the SVMI. The BSC-SVMIIM

systems are made up of open loop BSC-SVMIIM systems with disturbance and closed-two-loop PI and FOPID based BSC-SVMIIM systems. The Simulink was used to display and reproduce the results, which were then presented. The settling time and steady state error are used to assess the situation. The evaluations revealed a flawless implementation of the BSC-SVMIIM framework. In the recommended framework, lesser harmonic content and fast-time-retort are two preferences. In addition, the simulation outcomes validate the utility of the recommended BSC-SVMIIM.

**KEYWORDS:** *BSC-Boot Strap Converter, FOPID- Fractional Order Proportional Integral Derivative, SVM- Space Vector Modulation, IM- Induction Motor.*

#### INTRODUCTION

In the realm of motor drive systems, precision, efficiency, and robustness are paramount. Engineers are constantly exploring innovative techniques to enhance control mechanisms and optimize performance. One such advancement combines Fractional Order Proportional

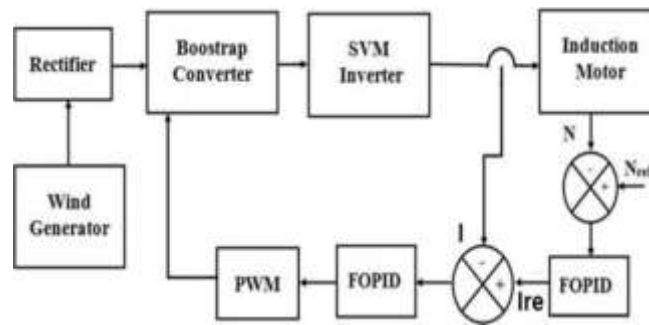
Integral Derivative (FOPID) controllers with Bootstrap Converters and Space Vector Modulation (SVM) Inverters to create a highly efficient and accurate Induction Motor (IM) drive system. This article delves into the architecture, advantages, and applications of this cutting-edge technology.

### Understanding the components

- 1. Fractional Order Proportional Integral Derivative (FOPID) Controller:** The conventional Proportional Integral Derivative (PID) controller has long been a staple in control systems. However, in complex systems with nonlinearities and uncertainties, the FOPID controller shines. It incorporates fractional calculus, allowing for more nuanced control over system dynamics. Fractional calculus enables the controller to handle fractional order differentiation and integration, offering enhanced robustness and stability.
- 2. Bootstrap converter:** The Bootstrap Converter plays a crucial role in providing the necessary voltage levels for the SVM Inverter. It efficiently steps up or steps down the voltage from a power source to match the requirements of the inverter. Its high efficiency and compact design make it ideal for various power electronics applications, particularly in motor drive systems.
- 3. Space Vector Modulation (SVM) Inverter:** SVM is a sophisticated modulation technique used to control the output voltage of inverters with exceptional precision. By synthesizing three-phase voltage vectors, SVM ensures efficient utilization of DC power while maintaining accurate control over motor speed and torque. Its ability to minimize harmonic distortion makes it particularly advantageous in high-performance motor drive applications.

### The fopid controller based BSC-SVMI

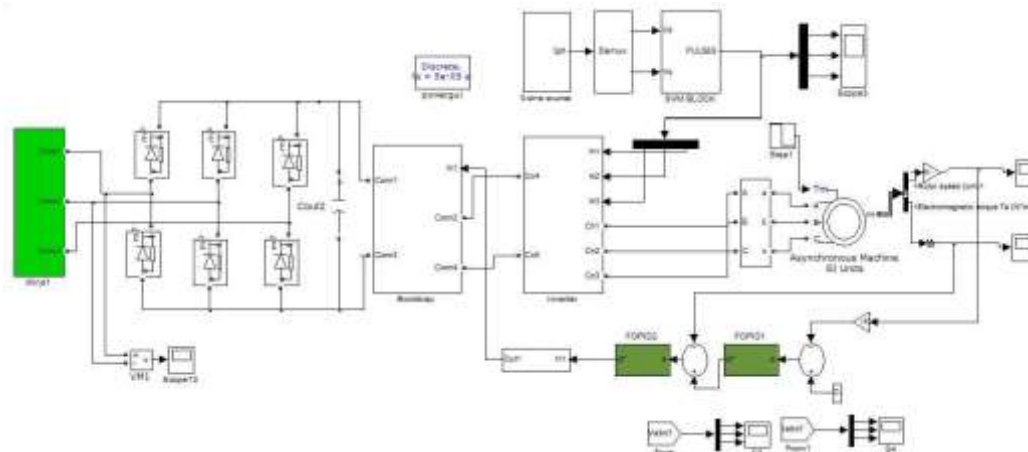
The Fig.1 depicts a schematic diagram of a FOPID-controlled BSC-SVMI setup. The speed of the IM is measured and compared to the rated speed to determine the speed error (SE). This SE is aimed at a FOPID-controller. To acquire reference current, the "yielding of FOPID" is applied. The current-error is delivered to a FOPID- controller once the reference current is compared to the actual current. The pulse width of BSC is adjusted using the results of FOPID.



**Fig. 1: Schematic representation of the BSC-SVMI System with Dual FOPID Controller.**

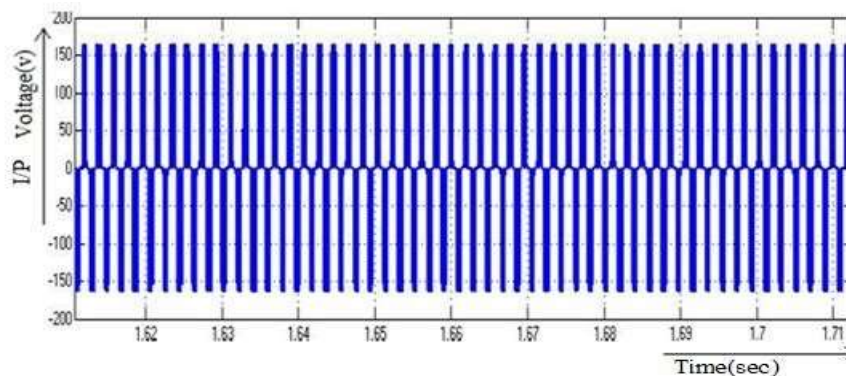
**Simulation results**

Fig. 2 shows a schematic diagram of a Bootstrap converter using an SVM inverter in a FOPID controlled two-closed loop system.

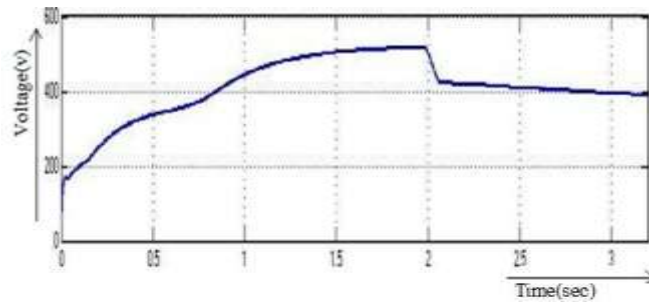


**Fig. 2: Schematic diagram of a closed-loop BSC-SVMI with a FOPID controller.**

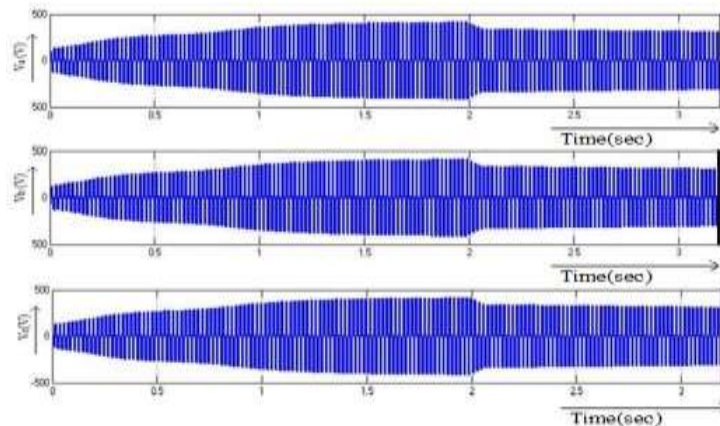
Fig. 3 shows the input voltage of the system with FOPID controller. The input voltage is set at 175 volts. Fig.4 shows the voltage across the bootstrap converter. Fig.5 shows the voltage across the motor loads, respectively. The voltage across the bootstrap converter equals 400 volts, while the voltage across the motor load is 480 volts at its peak.



**Fig. 3: Input voltage of the system with FOPID controller.**

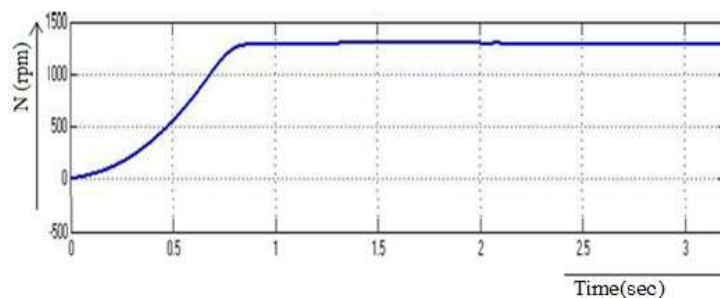


**Figs. 4: Voltage across the bootstrap converter.**

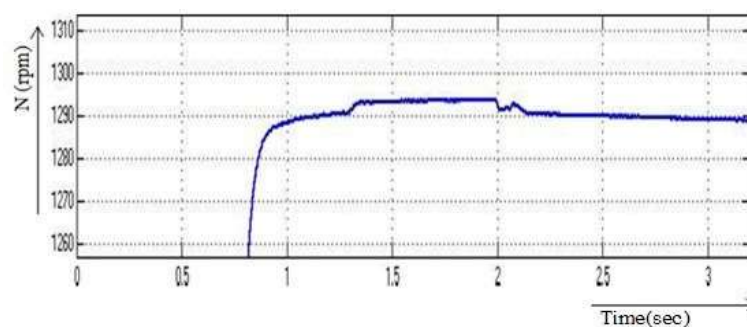


**Fig. 5: Voltage across the motor loads using FOPID controller.**

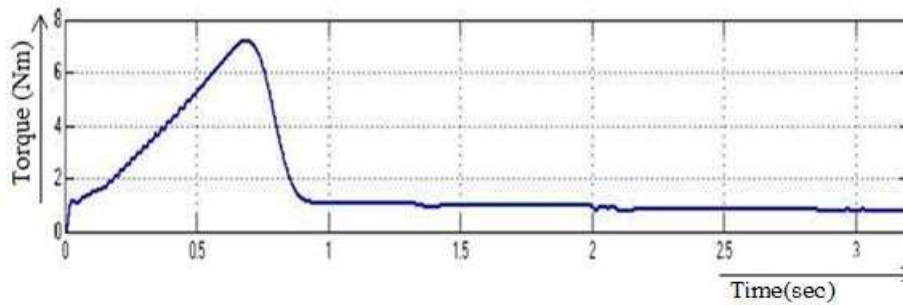
Fig.6 shows the motor speed of a two-closed loop BSC-SVMI with a FOPID controller, which is 1450 RPM. Fig.7 shows the motor speed zooming out of the two closed loop BSC-SVMI using the FOPID controller, which really is 1290 RPM. Fig.8 depicts the motor torque.



**Fig. 6: Motor speed of a closed loop BSC-SVMI using a FOPID controller.**



**Fig. 7: Motor speed zooming out of a closed loop BSC-SVMI using FOPID controller.**



**Fig. 8: Motor Torque of BSC-SVMI using FOPID controller.**

Table 1 compares time domain parameters for motor speed. The rise time is reduced from 1.37 to 1.35 seconds by employing the FOPID to FOPID-controller. The 'Settling-time' has been lowered from 2.63 seconds to 2.21 seconds. The peak time has been decreased from 2.46 seconds to 1.98 seconds. The steady state error has been lowered from 0.8 to 0.6.

**Table 1: Comparison of Time Domain Parameters for Motor Speed using PI and FOPID controllers.**

Type of Controller	Rise Times $T_r(s)$	Settling Time $T_s(s)$	Peak Time $T_p(s)$	Steady State Error $E_{ss}(rms)$
PI	1.37	2.63	2.46	0.8
FOPID	1.35	2.21	1.98	0.6

Table 2 shows the comparison of time domain parameters for motor torque. The rise time is reduced from 1.38 seconds to 1.36 seconds by employing a FOPID controller. The settling time has been reduced from 2.71 seconds to 2.23 seconds. The peak time has been reduced from 2.53 seconds to 1.89 seconds. The 0.5 steady state errors have been reduced to 0.4.

**Table 2: Comparison of Time Domain Parameters for Motor Torque using PI and FOPID controllers.**

Type of Controller	Rise Times $T_r(s)$	Settling Time $T_s(s)$	Peak Time $T_p(s)$	Steady State Error $E_{ss}(rms)$
PI	1.38	2.71	2.53	0.5
FOPID	1.36	2.23	1.89	0.4

### Applications

The FOPID controlled Bootstrap Converter with SVM Inverter-based IM drive finds applications across various industries.

- 1. Industrial automation:** Precise control over motor speed and torque is critical in industrial automation processes such as robotics, CNC machines, and conveyor systems. The high-performance characteristics of this system make it well-suited for such applications.
- 2. Renewable energy:** In renewable energy systems such as wind turbines and solar trackers, efficient motor drive systems are essential for maximizing energy capture and conversion. The integration of advanced control techniques ensures optimal performance and reliability in these applications.
- 3. Electric Vehicles (EVs):** The demand for electric vehicles continues to rise, driving the need for efficient and reliable motor drive systems. FOPID controlled IM drives offer superior performance, contributing to extended battery life and enhanced driving experience in EVs.

## CONCLUSION

The fusion of FOPID control, Bootstrap Converters, and SVM Inverters represents a significant advancement in motor drive technology. By leveraging the unique capabilities of each component, engineers can design highly efficient, precise, and robust motor drive systems for a wide range of applications. As industries continue to prioritize energy efficiency and performance, the adoption of these advanced control techniques is expected to proliferate, ushering in a new era of motor drive innovation.

## REFERENCES

1. Lee Empringham, Johann W.Kolar, Jose Rodriguez, Pat W.Wheeler and Jon C.Clare, "Technological issues and Industrial Application of Matrix converters: A Review", IEEE Transaction on IE, 2013; 60, 10: 4260-4271.
2. Ashwin kumar sahuo, J.Meenakshe, S.S Dash and T. Thyagarajan. "Analysis and simulation of Matrix Converter using PSIM", The International conference on Power Electronics, 2008; 7: 22-26, 414-419.
3. Sharon D.Ronald, A.Sheela, S. Josephin mary, "Three phase to three phase Direct Matrix converter using SPWM Technique", International journal of Soft Computing and Engineering (IJSCE) ISSN:2231-2307, 2013; 3: 2.
4. Millaanovic, M. Dobaj. B, "A novel unity power factor correction principle in direct AC to AC matrix converters", Annual IEEE Power Electronics Specialists conference, 1998;



- 29, 98, 1, 17: 1998-22, 746-752.
5. Lara, Guzman. V, Restrepo. J, Gimnez. M.I, Cabello. A, “Matrix converter induction motor Drive with DTC based Fuzzy control”, International Universities Power Engineering Conference, UPEC, 2007; 42.
  6. Johann W. Kolar, Frank Schafmeister, Simon D.Round, and Hans Ertl,, “Novel three Phase AC-AC Sparse Matrix converters”, IEEE transaction on Power Electronics, 2007; 22: 5.
  7. K.I.Hwu, C.F.Chuang and W.C.Tu,” High voltage boosting converters based on bootstrap capacitors and boost inductors”, IEEE trans. On IE, 2013; 60: 6.
  8. W.Li & X.He, “Review of no isolated high step up dc/dc converters in Photovoltaic grid connected applications”, IEEE Trans, on IE, 2011; 58, 4: 1239-1250.
  9. H.Tao, J.L.Duarte, and M.A.M. Hendrix, “Line- interactive UPS using a fuel cell as the primary source,” IEEE Trans. I. E., 2008; 55, 8: 3012-3021.
  10. D.Nicolae, C.Richards, and J.van Rensburg, “Boost Converter with improved Transfer ratio”, in Proc IEEE IPEC, 2010; 76-81.
  11. B.Axelrod, Y.Berkovich, and A.Ioinovici, “Switched capacitor/ switched inductor structures for getting transformer less hybrid dc-dc PWM converters”, IEEE-Trans. Circuits Syst. I, Reg. Papers, 2008; 55, 2: 687-696.
  12. K.J.Hwu, and Y.T.Yau, “ Voltage boosting converter based on charge pump and coupling inductor with passive voltage clamping”, IEEE Trans. I.E, 2010; 57, 5: 1719-1727.
  13. W.Li and X.He, “ A family of isolated interleaved boost and buck converters with winding cross coupled inductors”, IEEE Trans, PE, 2008; 23, 6: 3164-3173.
  14. Dr. T. Govindaraj and M.Gunasegaran,, “ -micro inverter system based electric drive”, International Journal Of Advanced and Innovative Research, 2012; 2012: 458-467.
  15. Simulation Dr. T. Govindaraj, and V. Purushothaman, modeling of inverter controlled BLDC drive using four switch,” International Journal of Advanced and Innovative Research. ISSN: 2278-7844, 2012; 554-559.
  16. F. A. Patakor, M. Sulaiman and Z. Ibrahim. Comparison performance of induction motor using SVPWM and hysteresis current controller. Journal of Theoretical and Applied Information Technology, 2011; 30(1): 10-17.
  17. Sertac Bayhan, Hasan Komurcugil. Lyapunov-Function-Based Controller for Single-Phase NPC Quasi-Z-Frequency Ripple Energies, 2021; 14(1): 140; <https://doi.org/10.3390/en14010140>
  18. A.Antony, D. G. Immanuel. An Overview of Bootstrap Converter for Grid connected

Wind Energy Conversion System. 7th International Conference on Electrical Energy Systems (ICEES), 2021; 11-13, 515-523. DOI: 10.1109/ICEES51510.2021.

19. Guo, Y.; Yuan, F.; Chang, Y.; Kou, Y.; Zhang, X.. A Bootstrap Structure Directly Charged by BUS Voltage with Threshold-Based Digital Control for High-Speed Buck Converter. *Electronics*, 2021; 10, 2863: 1-14.
20. YongKeun Lee, JongKwang Kim. Analysis of Bootstrap Circuit Operation With an Inverted PWM Drive Scheme for a Three-Phase Inverter for a Brushless DC Motor Drive. *Canadian Journal of Electrical and Computer Engineering*, 2019; 42(1): 58-65.